

StitchLiner

VAC-100 + ST-40 + ACF-30 + SPF-30 + HTS-30

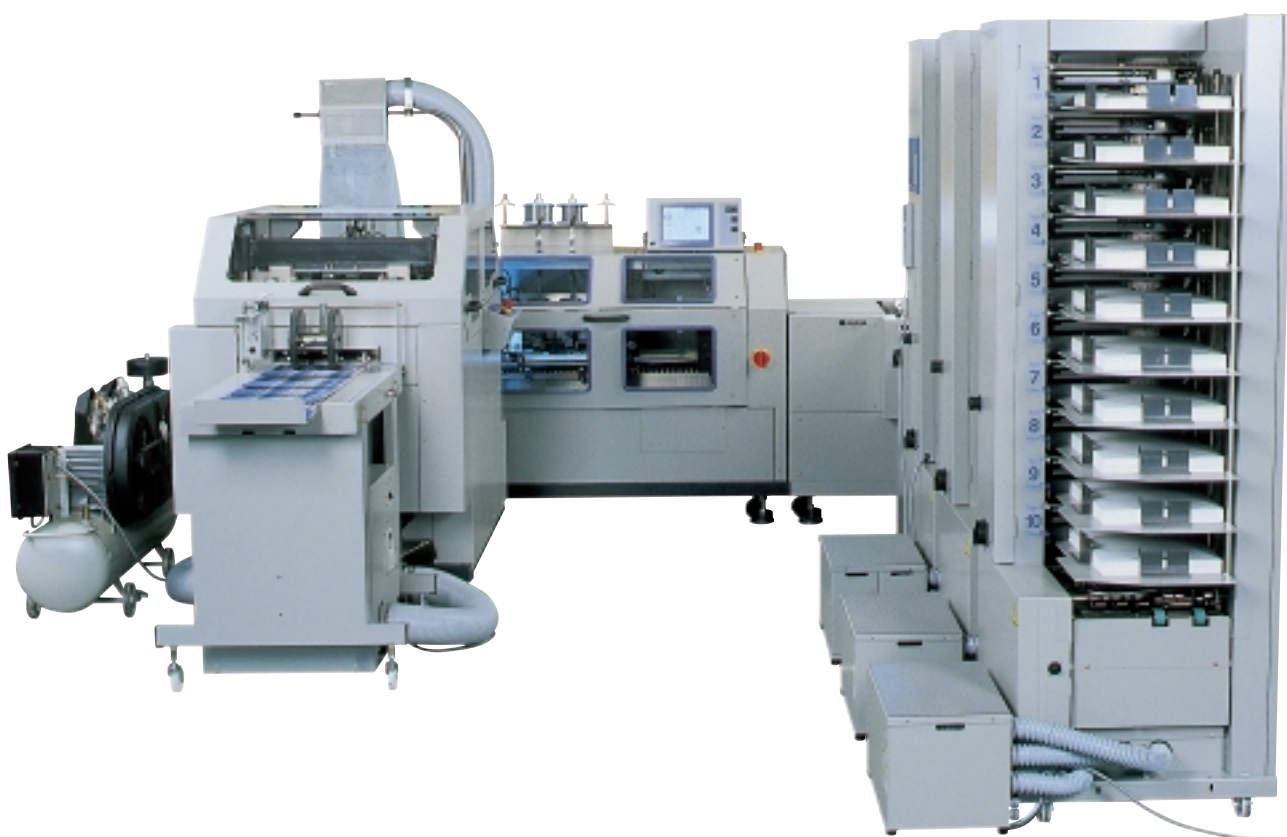

StitchLiner Components

Collator : VAC-100
 Stacker : ST-40
 Accumulator/Folder : ACF-30
 Saddle Stitcher : SPF-30
 Three-knife Trimmer : HTS-30

Option

Chip Extractor : TB-30

Major Specifications

Sheet Size (Width x Length)	Max.: 350 x 500 mm (13.7" x 19.6") Min. : 148 x 210 mm (5.9" x 8.3") (140 mm (5.5") by using optional support guide)
Sheet Weight Range	Bond Paper : 60 to 210 gsm Coated Paper : 80 to 210 gsm
Stitch Thickness	5 mm (0.2")
Booklet Size (Before Trim) (Top/Bottom x Fore-edge)	Max.: 350 x 260 mm (13.7" x 10.2") Min. : 140 x 105 mm (5.5" x 4.2")
Booklet Size (After Trim) (Top/Bottom x Fore-edge)	Max.: 312 x 230 mm (12.2" x 9.0") Min. : 120 x 85 mm (7.8" x 3.4")
Production Speed	Max.: 5,500 booklet/hr.
Voltage/Frequency	3-phase 200V 50/60Hz 3-phase 220V 60Hz 3-phase 400V 50Hz
Weight	ACF-30 : 260kg (573.3 lb) SPF-30 : 730kg (1,609.7 lb) HTS-30 : 1,000kg (1,163 lb)

StitchLiner Layout

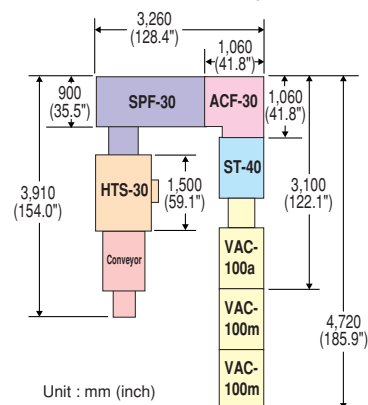

Horizon

Saddle Stitching System

Introducing a new concept in booklet production merging simplicity of flat sheet collating with the high productivity and quality finish of saddle stitching and three knife trimming.

1. At 5,500 booklets/hr., the StitchLiner is ideal for short to mid range production runs.
2. A simple, icon-based touch screen provides for quick and easy set-up of the finishing sections with full automation
3. Scoring and plow-folding ensure the tight folds and flat finished booklets. Off-line signature folding is completely eliminated.
4. Space efficient U-shaped system allows for easy, single-person operation and monitoring of complete system.

Collator : VAC-100

- Up to six 10-station VAC towers can be combined to create a sixty-station collating system.
- Powerful VAC programming features permit continuous productivity.

Accumulator/Folder : ACF-30

- Sheets are accumulated by section, scored, and then plow-folded.
- The number of sheets per folded section can be varied to insure a tight fold, depending upon sheet count, grain direction, or paper weight.

Saddle Stitcher : SPF-30

- Up to 5mm can be gathered on the saddle for heavy-duty stitching.
- Two stitcher heads are standard. Up to two additional heads can be added for two-up booklets. Loop stitching option available.
- Five selectable operating speeds, depending on job configuration and stock quality.

Three-knife Trimmer : HTS-30

- In-line three-side trimming provides complete, high-quality finishing in one pass.
- Center-cut option provides for two-up booklet production.
- All cut parameters are input at the centralized touch-screen, with full automation.
- Optional batch kicker separates one-up or two-up booklet streams at a predetermined count.

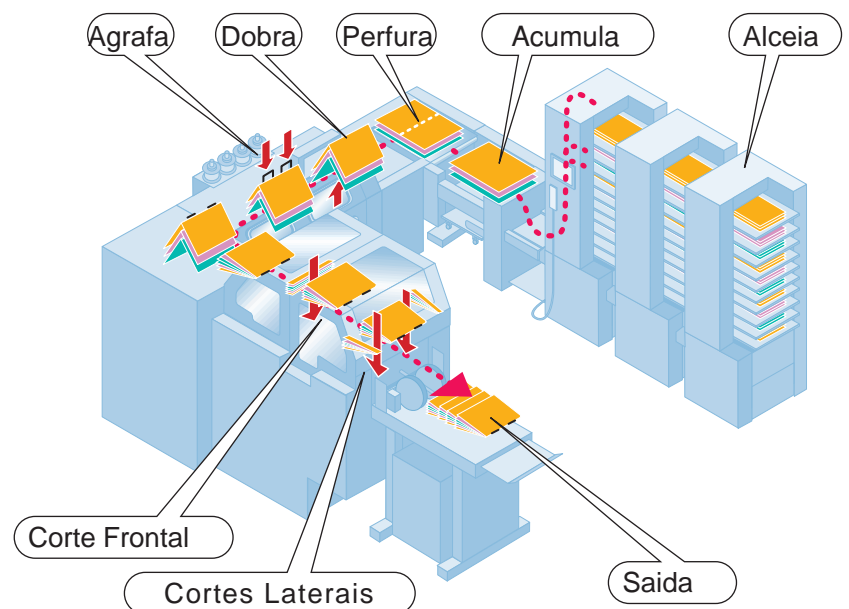

Todo o sistema de trabalho da linha "StitchLiner"